

What we claim as our invention and desire to secure by Letters Patent for Canada is:-

1. In a tobacco pipe, cigar holder or cigarette holder, a loose tube fitting within the bore, such tube being of uniform external diameter and provided with a narrow projecting part such for instance as a disc, bead, stamped or pressed protuberance or the like thereon, adapted to be held in a recess or between the holder and the mouthpiece, when the latter is fixed in position so that the tube cannot move in either di-

6
rection.

2. In a tobacco pipe, cigar holder or cigarette holder, as claimed in claim 1, the construction in which a recess is provided in the stem of the pipe or in the holder portion, into which the disc or its equivalent on the tube fits, and in which a projection is provided on the mouth piece, adapted to come down upon and rest upon the said disc or its equivalent when in position and to hold the tube with one end extending to, or into the bowl or holder and the other end extending to the neighbourhood of the end of the mouth piece, substantially as described.

3. A modified form of pipe, cigar holder or cigarette holder, as claimed in claim 2 in which the recess for the ~~mouth~~ ~~piece~~ reception of the disc or its equivalent upon the tube is provided upon the mouth piece, and the projection upon the stem of the pipe or upon the holder, substantially as described.

4. A constructional form of tobacco pipe as claimed in the preceding claims, in which the tube is provided with a shaped or cut away portion adapted to pass into the bowl and in which the disc or the fitting parts are so shaped that the tube can only be inserted in the correct position within the bore, substantially as described.

This invention relates to tobacco pipes, cigar holders, and cigarette holders and refers to that type of such devices in which a loose tube is provided adapted to be inserted into the bore of the pipe or the like, and to form a conduit along which the smoke will pass, the said tube being easily removable for cleaning purposes.

Various arrangements have already been proposed for holding the loose tube in position.

It has for instance been proposed to make this loose tube from a piece of two diameters, the portion of larger diameter resting in a recess in the stem of the pipe and the portion of smaller diameter in a recess in the mouth piece, or again it has been proposed to provide an inner tube of uniform external diameter resting at one end against a ledge in the mouth piece and at the other end passing into the bowl or resting against a ledge or taper in the neighbourhood of the bowl.

Our present invention relates to an improved and simplified construction in which the removable tube, which is of uniform external diameter is provided with a narrow projecting part, such for instance as a disc, bead, stamped or pressed protuberance or the like thereon, adapted to be held in a recess formed between the stem of the pipe and the mouth piece or between the holder and the mouth piece, when the latter is fixed in position, so that the tube cannot move in either direction.

In the preferred construction, we provide a recess or counter-sunk hollow in one of the parts, that is in the pipe or holder or in the mouth piece into which fits a projection on the other part, so that when the tube is in position with the disc or its equivalent in the recess, and the mouth piece is attached, the disc or its equivalent is gripped between the parts and will not move in either direction, the end of the tube reaching to or into the bowl of the pipe, as may be desired, or to a suitable distance with respect to one end of the holder, and the other end extending to the neighbourhood of the end of the mouth

piece.

At the same time in order to remove the tube for cleaning or other purposes, it is simply necessary to remove the mouth piece when the tube can be immediately disengaged.

And in order that our said invention may be clearly understood we will now proceed to describe the same with reference to the accompanying drawing, in which :-

Fig 1 shows a longitudinal section of a tobacco pipe with our invention applied thereto,

Fig 2 shows a longitudinal section of a cigar holder or cigarette holder, with our invention applied thereto.

Figs 3 and 4 show elevation of a modified form of the inner tube.

Referring to Fig 1, the stem portion a of the tobacco pipe is provided with a recess or hollow a¹ from which opens the bore a² of the pipe. The mouth piece portion b is provided with a part b¹ adapted to fit into the recess a¹.

c is a tube of aluminium or other suitable metal or material formed or provided with a disc d. This disc is adapted to pass into the recess a¹ and rest at the end thereof, and the parts are so proportioned that when the mouth piece b is placed in position it comes down upon the disc d and holds the tube firmly in position, the tube being of such length that it extends almost to the bowl of the pipe.

In Fig 2 where the device is shown fitted to a cigar or cigarette holder, the holder portion e is provided with a recess e¹ and the mouth piece f with the extension f¹ for holding the disc d and consequently the tube c in the correct position.

In some cases an additional disc or washer of cork or other material may be added, especially in the case of a pipe if found desirable.

It will be understood that the countersunk recess or hollow may be provided either in the holder or stem of the pipe, as shown, or in the mouth piece.

In place of providing a flange d I may provide other equivalent means on the tube c for preventing the said tube moving in either direction, In Fig 5 the tube is shown provided with a stamped enlargement d¹ adapted to rest in the recess between the stem and the mouth piece portion whilst in Fig 4 the tube is shown provided with a projection or band d² for the same purpose.

In some cases where it is desired to prolong the tube c into the bowl of the pipe and furnish it with an opening at one side extending into the bowl it is desirable to provide means for registering the position of the tube c in the bore.

To effect this various expedients may be adopted.

For instance we may make the recesses g¹ g² of special shape and form the flange or plate d and the projecting part b¹ or f¹ of special shape so that the parts can only be put together with the tube in one particular position.

We may also provide a simple step or pin upon the flange or tube passing a corresponding polygonal form: where it is required that they should only fit together in one particular position, the polygon being an irregular one.

In some cases the disc may be provided with a roughened surface, for holding it in position, which is particularly desirable where a disc of cork or other washer is ~~required~~ pressed against the disc in order to make the fitting perfectly tight.

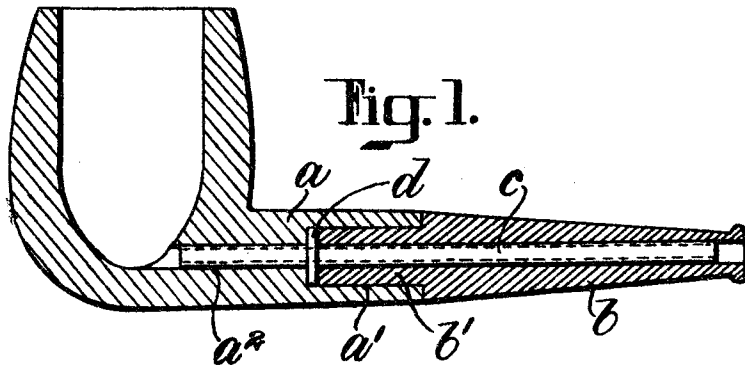

Fig. 1.

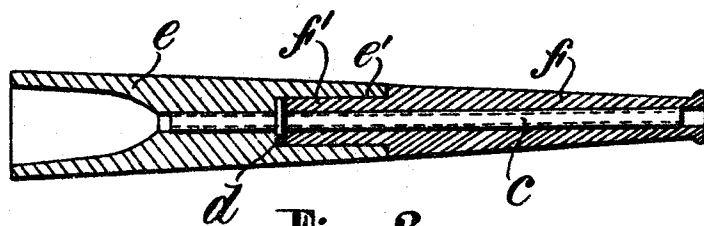

Fig. 2.

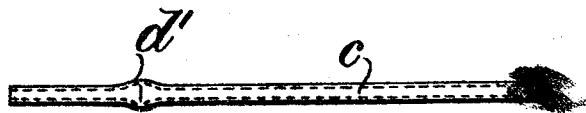

Fig. 3.



Fig. 4.

Certified to be the drawings referred to in the specification hereto annexed, Ottawa,...

June 20. 1917
Inventor.

A. Dunhill
J. G. Mauderville

By J. H. Sturtonhaugh

Witnesses.

P. Yarrow.
M. Cameron